



APPLICATION NOTE

LuxaPrint Model

Validated workflow with DMG DentaMile



Application Note: LuxaPrint Model

The basis for precise work

The dental model is an important part of the digital workflow. LuxaPrint Model is a light-curing precision resin for the manufacture of various 3D print models – whether complete or partial models, with or without removable dies solid or hollow for aesthetically demanding work.

Top class, mechanically and optically

The surface of models created with LuxaPrint Model is exceptionally fine, smooth and pore-free. The models offer very high detail reproduction and excellent detail precision. The opaque colour chosen allows for optimal identification of all model contours and preparation margins on study models and provides the corresponding basis for highly precise prostheses.

Thanks to maximum surface hardness and dimensional stability, the models meet highest demands for mechanical properties.



Validated workflow with DMG DentaMile

In this application guide, we present our validated DentaMile workflow, which you can use to easily and reliably achieve a result that meets the high requirements of dental users in terms of biocompatibility, stability and precision.

The DentaMile workflow was developed at DMG according to strict criteria, and carefully tested in our digital application centre. Please follow the below procedure exactly. That way, you can rest assured that you will always deliver work of the highest quality.



Table of contents

1. Scan	6
2. Design (e.g. exocad, 3Shape, BISS)	7
3. Print preparation	13
4. Printing	30
5. Post-processing	31
6. Validated fitting accuracy	38

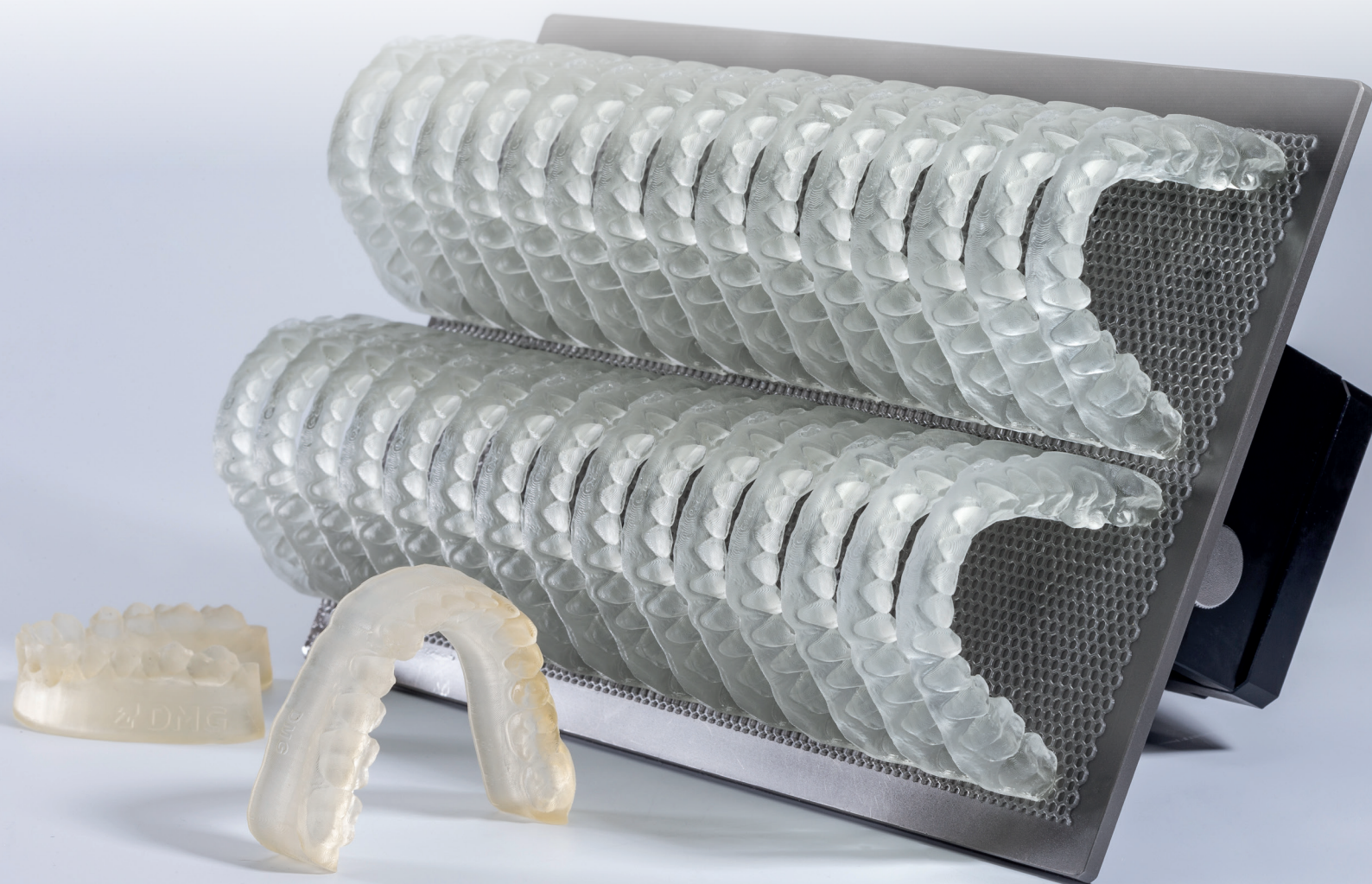

Required equipment and resources

▶ SCAN

Digital scanner or optical desktop scanner

▶ DESIGN

Dental design software for designing models (e.g. exocad, 3Shape, BISS)

▶ PRINT

The following table lists all of the 3D printer and post-process device combinations suitable for printing with **LuxaPrint Model (DMG)** using our validated workflow. The printers should always be used with the appropriate slicing software with the validated printing parameters (e.g. Autodesk Netfabb for DMG DentaMile Lab5 (Pro), 3Demax and 3Delite or DMG DentaMile CAM MC for DMG DentaMile Desk MC-5).

Printer	Cleaning unit	Post-curing	Colour variants
DMG 3Demax DMG 3Delite DMG DentaMile Lab 5 (Pro)	DMG 3Dewash Ultrasonic bath	DMG 3Decure Otoflash G171	Beige (BGE) Grey (GRY) Ivory (IVR) Transparent (TRA)
DMG DentaMile Desk MC-5	DMG 3Dewash	DMG DentaMile Cure MC	Beige (BGE) Grey (GRY) Ivory (IVR) Transparent (TRA)
RapidShape D10+ RapidShape D20+ RapidShape D50+	RS Wash Straumann P Wash Ultrasonic bath	RS cure Straumann P Cure Otoflash G171	Beige (BGE) Grey (GRY) Ivory (IVR) Transparent (TRA)
Asiga MAX UV	Ultrasonic bath	Otoflash G171	Beige (BGE) Grey (GRY) Ivory (IVR) Transparent (TRA)
Ackuretta SOL	Ackuretta Cleani	Ackuretta Curie	Grey (GRY) Transparent (TRA)



1. Scan

In order to create a digital model, it will first be necessary to generate digital patient data. This can be done at the dental practice with a digital scanner or in the dental laboratory with a laboratory scanner. Depending on the version, impressions of the patient's teeth or plaster models can be scanned directly with the laboratory scanner.

The quality of the digital model plays a key role in ensuring that treatment is smooth and its success. Due to the fact that the digital models will only ever be as good as the intraoral scans or impressions on which they are based, it is important to ensure that they are of the highest possible standard. When creating study models, it is also important to ensure that the preparation margins are clearly defined.

PRACTICAL TIP

We recommend using a layer thickness of 50 µm when creating master models with removable dies to guarantee that the dies can be fitted reliably and with precision.

2. Design (e.g. exocad, 3Shape, BISS)

The way dental models are designed can differ depending on the models' purpose. The two main model types are master models, which are used for e.g. restorative work, and diagnostic models, which are used as orthodontic plate models or for creating occlusal splints with 3D Printing devices. However, there are also significant variations in the approaches taken to create these main types, depending - again - on their purpose. Creating dental model casts, for example, requires master models that include the palate, while creating a single crown only requires a part of the jaw with a removable tooth die

There are furthermore various design principles for 3D-printing these models that vary depending on the models' purpose. This Application Note explains in detail how to create master models with removable dies and diagnostic models for creating splints with 3D Printing. The design guidelines presented in the following can also be easily applied to other types of models.

The following table provides an overview of which of our LuxaPrint materials and layer thicknesses are suitable for which model types.

Model type	Material	Layer thicknesses
Master models	LuxaPrint Model, Grey (GRY) LuxaPrint Model, Beige (BGE) LuxaPrint Model, Ivory (IVR)	50 µm
Diagnostic models	LuxaPrint Model, Transparent (TRA) LuxaPrint Model, Grey (GRY) LuxaPrint Model, Beige (BGE) LuxaPrint Model, Ivory (IVR)	50- 150 µm

PRACTICAL TIP

When creating dental models that only comprise a dental arch (without sections of the palate or a base), we recommend adding a supporting bar for greater stability.

This is because the process of post-curing the printed objects gives rise to polymerisation-induced tension in the material. This is normal for printing resins and, in the widest sense, is caused by changes in the material's density, which make the two sides expand and hence reduce precision.

Regardless of the program you use, the following material-specific specifications should be followed:

Minimum printed object wall thickness	2 mm
Maximum printed object wall thickness	7 mm
Height of stump models	min. 21 mm
Supporting bar for models without palates	√
Hollowing out models	√

To create a model, start by importing all of the patient data into the design software. The software will guide you through every step of the dental model design process. Make sure you follow the software developer's specifications.

Creating a good model is crucial to a treatment's success. Our 3D printers and materials are set up so that the digital data can be reproduced with great precision. Hence, the model should be created with a corresponding level of care.

Supporting bar for stabilising models without palates

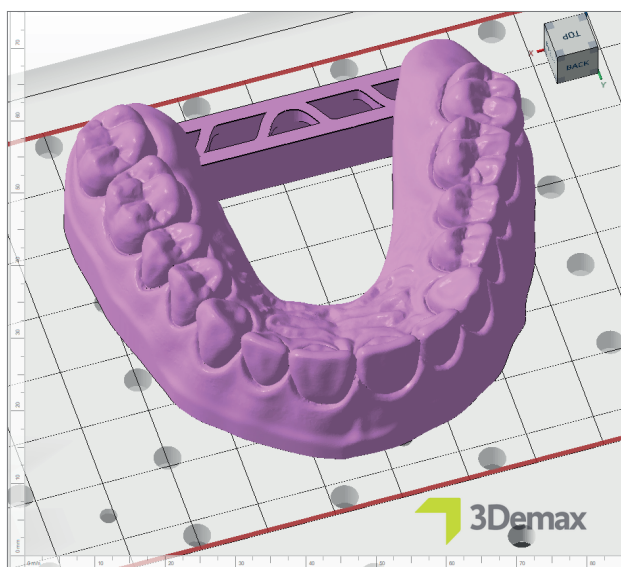

For detailed instructions on how to design dental models, please contact your software manufacturer.

2.1. Models with removable dies

When creating models with removable dies it is crucial that the printed objects are completely accurate and that the dies are properly fitted inside the sockets. In view of the fact that even minor deviations from the workflow can result in significant changes when fitting the dies it is important to approach this process with a great level of care.

Please check whether your software has already been set up for LuxaPrint Model (DMG). The design programs and print systems listed here have already been validated at the time this document was printed. More programs and print systems are going to follow. If your system has not yet been set up, you can establish the right settings yourself using a design model. In general, this only needs to be done once for a workflow (combination of design software, printer, material, material parameters and post-curing conditions). The most important setting is the gap between the die and socket (also referred to as the **horizontal gap**).

2.1.1. exocad - Models with removable dies

Start as usual by creating a new order in exocad and then open the **Model Creator**. Select **Plateless Model - cutout dies** as the model type and trim your imported scan data, if necessary.

After you have selected removable teeth and defined the preparation margins, you can specify the model and die properties. Combining these settings in the right way will result in a reliable and perfectly fitting die and high-quality model. The settings suggested here have been developed by dental technicians in our digital Application Centre and will result in models with excellent properties and validated 3D print precision. When using other system, the optimum settings for the horizontal gap may differ.

PRACTICAL TIP

The model type **Plateless Model - extra dies** creates a model with fixed dies and separate removable dies for fitting the restorative work. With this model type, there is no need for fitting the dies which means there is also no need to establish appropriate gaps. If this meets your needs, this will allow you to create a perfect and functional model with every print.

PRACTICAL TIP

There are also many other parameter combinations that can produce very good results. Please note that, in these cases, the information about the gap widths may not apply.

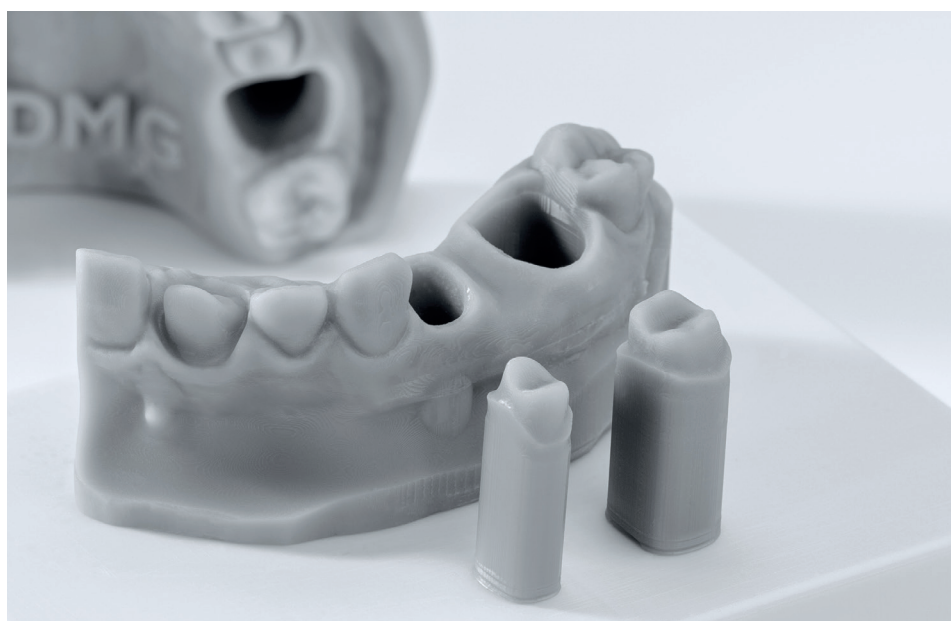

Design parameters for exocad

Validated with the DentaMile Workflow:

Printer	Cleaning unit	Post-curing	Materials
DMG 3Demax DMG 3Delite DMG DentaMile Lab 5 (Pro)	DMG 3Dewash Ultrasonic bath	DMG 3Decure Otoflash G171	LuxaPrint Model, Beige (BGE) LuxaPrint Model, Grey (GRY) LuxaPrint Model, Ivory (IVR) LuxaPrint Model, Transp. (TRA)

Presettings:		DMG – 3Demax LuxaPrint Model Beige/Grey/Ivory/Transparent – (hollow model)		
Basis				
Horizontal gap	0.02 mm / Grey	0.02 mm / Beige	0.01 mm / Ivory	
Vertical gap	0.08 mm			
Base height	3 mm			
Exposure		√		
Width	0.1 mm			
∅ Depth	0.6 mm			
∅ Height	0 mm			
Recess pins		√		
Width	2 mm			
Depth	1 mm			
Hollow model		√		
Wall thickness	3 mm			
Base sill	1 mm			
Hollow area diameter	3 mm			
Stumps				
Pin height	1.5 mm			
Extrusion finish line	0.15 mm			
Wide contact area	1.5 mm			
Shaft taper	3° / Grey	3° / Beige	0° / Ivory	
Taper height limit	7 mm			
Chamfer preparation	√			
Bottom side of the stump parallel to the base of the model	√			

Under **Add attachments**, select **Transversal Connector ... mm** (or an equivalent connector), to insert a simple bar between the two sides of the model. This will be necessary in order to make sure that the printed objects are as accurate as possible (see also the “Practical tip” about stabilisation bars in Section 2).

2.1.2. 3Shape - Models with removable stumps

Please use the following settings for creating a model in 3Shape. These settings may not apply when using other print systems.

Validated with the DentaMile Workflow:

Printer	Cleaning unit	Post-curing	Materials
DMG 3Demax DMG 3Delite DMG DentaMile Lab 5 (Pro)	DMG 3Dewash Ultrasonic bath	DMG 3Decure Otoflash G171	LuxaPrint Model, Grey (GRY)

Settings:	LuxaPrint Model, Grey
Die fitting	
Distance between die and model	0.1 mm
Friction bar width	0.7 mm
Number of friction bars	8
Model production process	
Hollow out model	√
Minimum height of model base	2 mm
Panel thickness	2.5 mm
Size of bottom drain hole	5 mm
Side drain holes	√
Type	CADCylindricalSideDrainHole 3x3
Centre height	3 mm
Gap	10 mm
Articulator	Simple Full Arch v2.3

2.2. Diagnostic models

Diagnostic models are created in the same way as study models. Due to the fact that there will be no need for die fitting, there will be fewer restraints when choosing the model's properties. When creating models for vacuum-formed splints, you only need to provide the data for a dental arch with or without a base and with a low model height. This will save material and time when it comes to printing the object. To ensure a maximum level of reproduction accuracy, it will also be necessary to insert a connecting bar between the back teeth.

Example of a diagnostic model

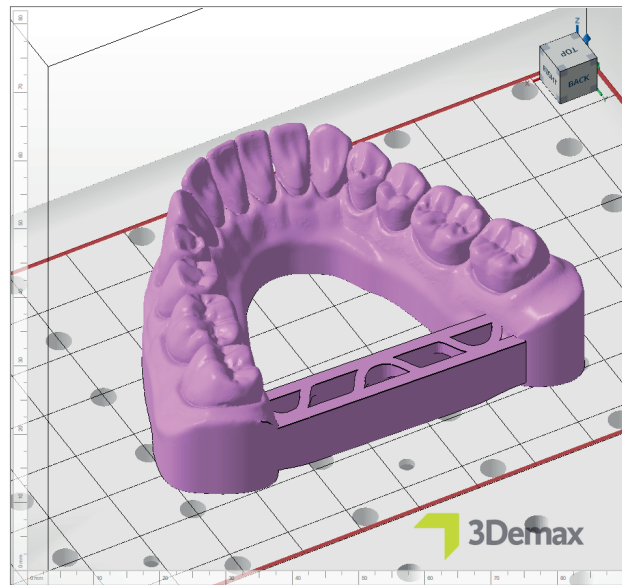

PRACTICAL TIP

Please always ensure that the correct machine and material parameters are used. Incorrect settings can lead to misprints and models with a bad fit, as well as inadequate mechanical properties.

3. Preparing the print

The digitally designed model and the associated dies must now be imported into the printer software in order to prepare them for 3D printing.

In this step, the models and dies are oriented, arranged and then provided with support structures in the build area of the printer.

3.1. Autodesk Netfabb for DMG DentaMile Lab5 (Pro), DMG 3Demax, DMG 3Delite and RapidShape D-series

3.1.1. Selecting the material and machine

Open Autodesk Netfabb and select your machine environment (e.g. DMG 3Demax).

The DMG workflow area appears on the right-hand side of the screen (marked by the blue DMG logo). Here, you will be guided through all the relevant steps of the software from start to finish.

DMG workflow area in Netfabb

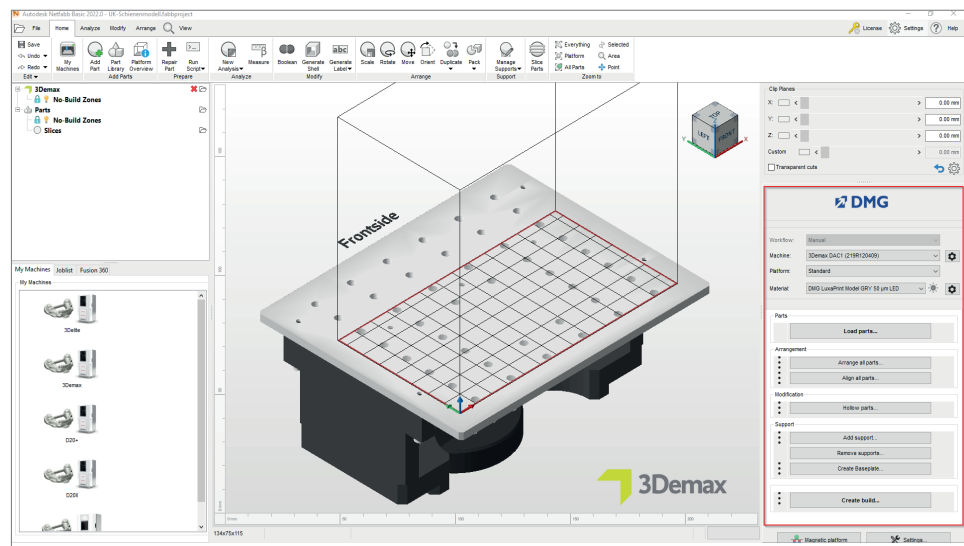

First select your printer and the material **LuxaPrint Model (DMG)** in the corresponding colour option as well as the required layer thickness. If you have never worked with the material, you may have to use the setting wheel next to the material line to create it (see 3Demax/3Delite operating instructions, point 6.7).

LAYER THICKNESSES

All available layer thicknesses have been checked in our digital application centre and deliver an exact and reliable printed object. A lower layer thickness leads to a finer surface structure, higher accuracy and longer printing time. Choose the correct layer thickness depending on your specifications at the time available and the desired surface quality. For models with removable dies we recommend a layer thickness of 50 microns.

3.1.2. Importing in Netfabb

Import the previously created model design into Netfabb. To do this, simply drag your file into the program's 3D view or select the item **Load Pieces...** in the DMG workflow area and navigate to your design. The imported objects will then immediately appear in the 3D view.

Importing in Netfabb

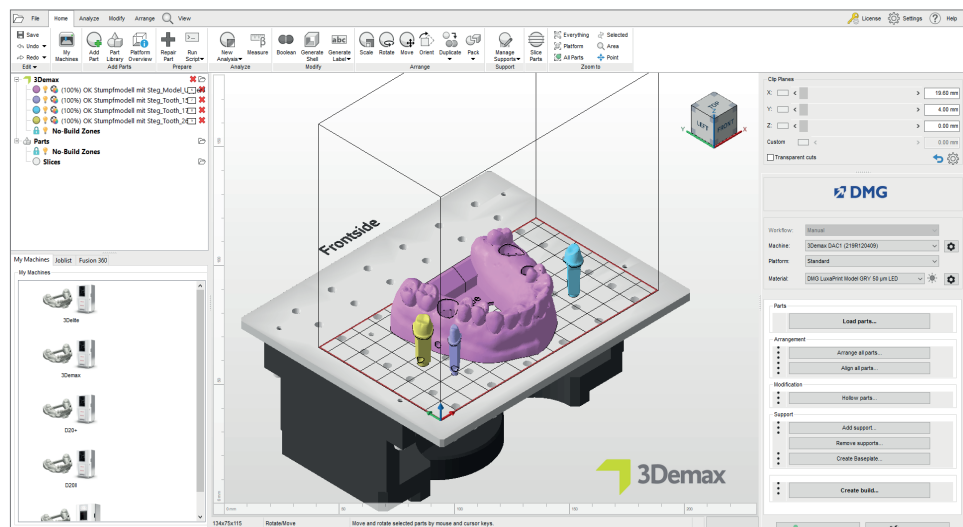

3.1.3. Aligning the models

Arrange the objects on the build platform. Activate the **Magnetic platform** function to make sure that the objects stay on the build platform when moving them.

If an object is upside down, press the **Rotate** button while the part is activated to rotate it. If rotating it, make sure that the object's bottom is resting flat against the build platform.

Optimal orientation for models in DentaMile CAM MC

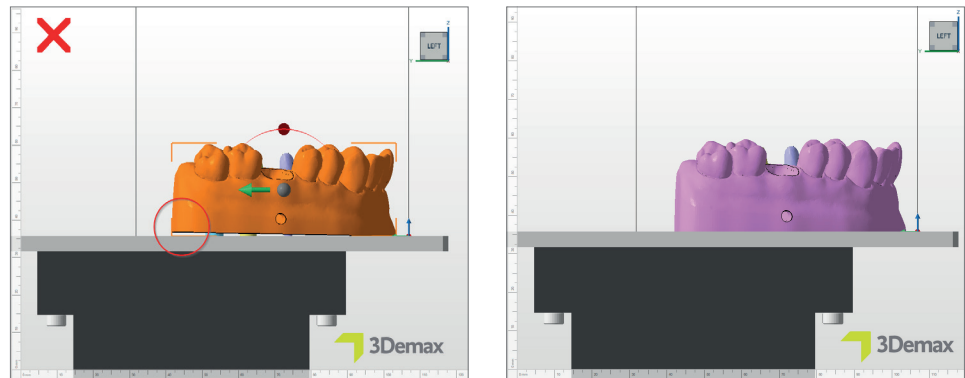

The option **Align** (Tab **Arrange** → Group **Align** → Option **Align**) can be very helpful for changing the orientation of objects. Once you have selected the relevant object, select the above option and click on the surface that you want to contact the build platform (which is generally the bottom of the model). The object will subsequently align itself automatically and should then be resting on the build platform with the selected surface.

Next, proceed with the dies in the same way as with the model. If you are using the design software settings suggested above, the dies will already be in an upright position on the build platform after the import. If that is not the case, please use the **Align** function.

Move the dies into the centre of the area on the build platform that does not have any holes. This area has been especially designed for the dies and ensures that they are not above the holes on the build platform, and that they can be printed without any errors. If there is not enough space or if you are using models with palates, they can also be positioned outside the model.

Aligning the dies in Netfabb

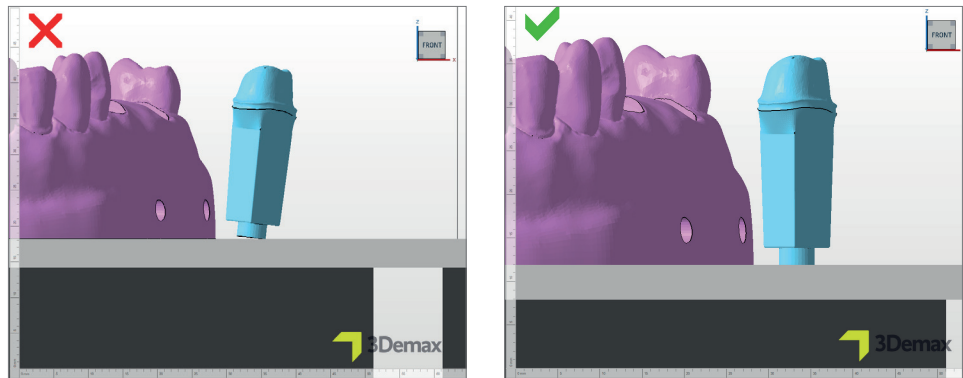

Take a birds-eye view of the objects to make sure that they are all in adequate contact with the build platform. In Netfabb, the surface area of the build platform has a slightly different colour (see image below).

Ready aligned models and dies in Netfabb

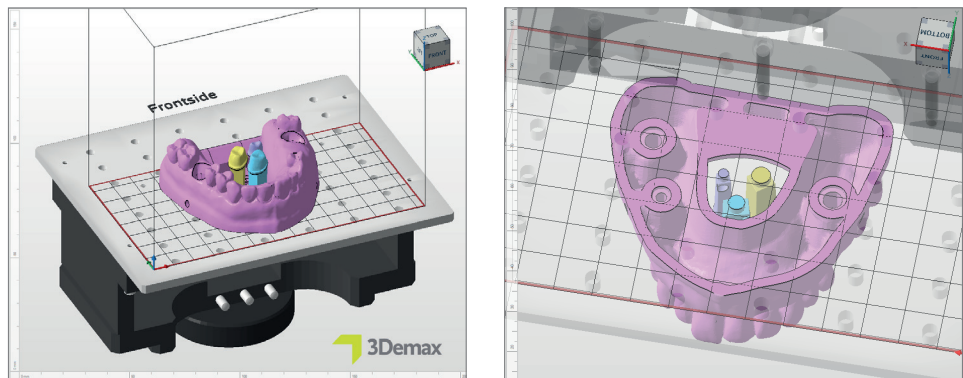

3.1.4. Adding support structures

Due to the fact that the models are usually printed directly on the build platform, there is not necessarily any need for support structures. However, when printing hollow models, it is still advisable to use them to increase the objects' stability during printing and hence to prevent printing errors and achieve a higher level of accuracy.

First, select your model (not the dies with a left-click and then **Add support ...** in the DMG workflow area. In the next dialogue window, click on **Use integrated support** and select Model from the drop-down menu. The menu item **Lift components in front of support (in mm)** has to be deactivated for the model to continue to rest flat on the build platform.

Support settings in Netfabb

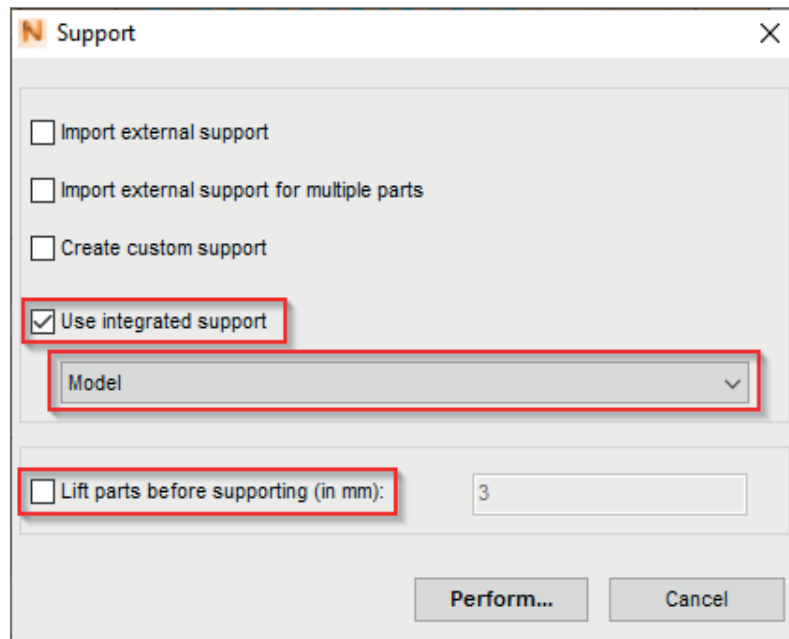

The program automatically calculates the optimal position of the support structures and inserts them between the building platform and the model.

View of the model including supports from below

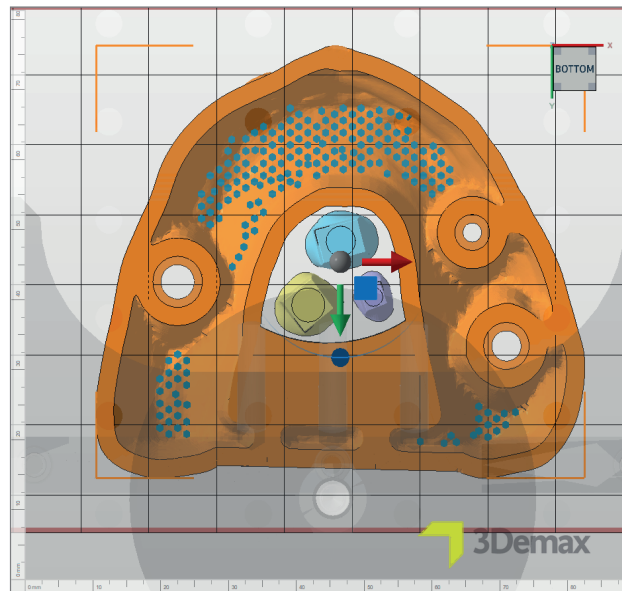

The tooth dies do not require any support structures if they have been created with the above parameters because they will be securely resting on a small base (or pin).

3.1.5. Baseplate

A baseplate makes the model rest more securely on the build platform and increases its stability around the base. You should always use a baseplate when printing with LuxaPrint Model.

First, select your model (not the dies and then click on **Generate baseplate...** in the DMG workflow area. Please use the settings shown in this illustration for doing so.

Baseplate settings

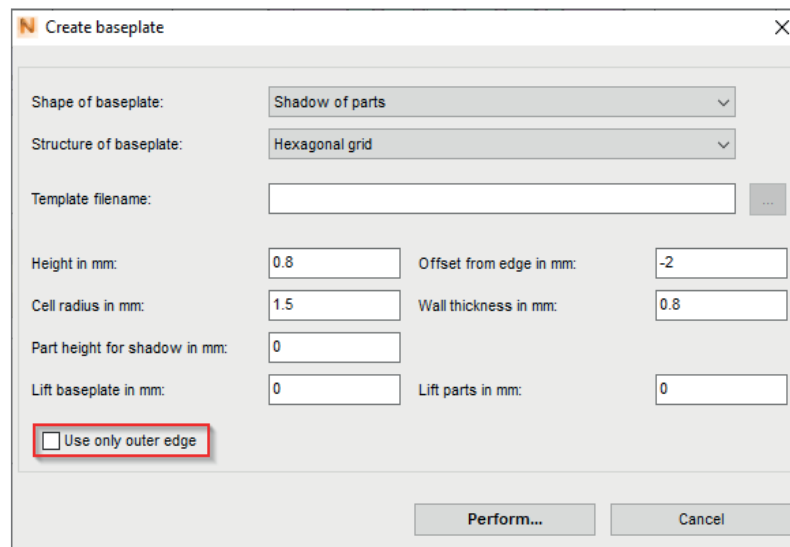

After adding the supports and baseplate, the model should roughly look like the one shown here when looking at it from below:

Ready-to-print model with support structures and hexagonal baseplate

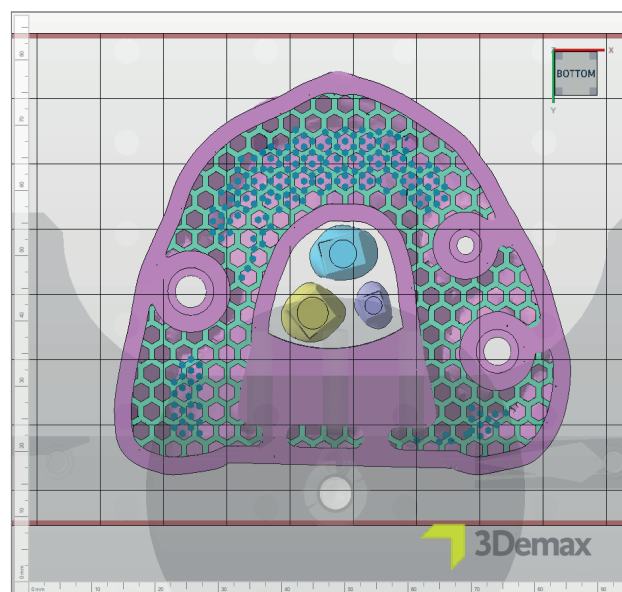

3.1.6. Creating a build job and transferring it to the printer (slicing)

Once you are happy with the way the model and stumps are arranged on the build platform, check the material and machine settings again. Next, click on **Create build job** to create a printer-readable file in the DMG workflow area, which is the build job.

After the calculation of the individual print layers, which is called 'slicing', a preview window with the selected machine and material settings, as well as a black-and-white diagram view of the individual print layers will open. Here, you can scroll through the layers of the print job and review your object.

Now, transfer the finished print job to your 3D printer via a network connection or USB stick.

Print preview in Netfabb

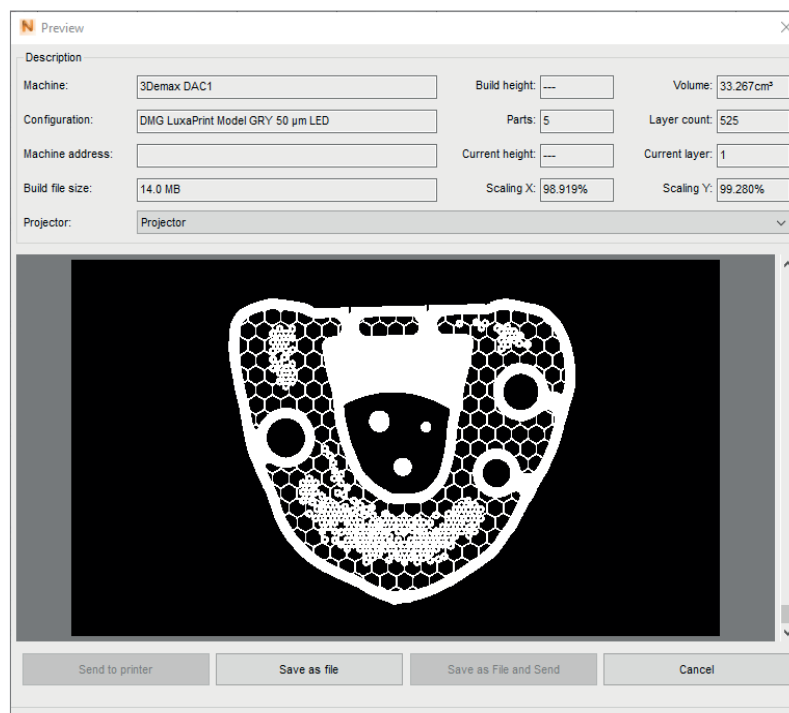

3.2. DentaMile CAM MC for DentaMile Desk MC-5

3.2.1. Select the printer and material

Open DentaMile CAM MC and select your printer (DentaMile Desk MC-5) and the right material and print profile for your LuxaPrint Model resin.

Select the printer and material parameters

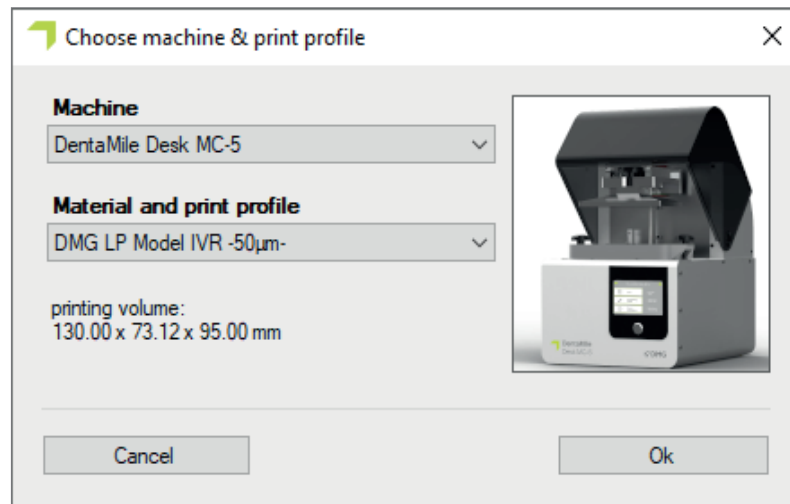

The DentaMile CAM workflow area can be opened by clicking on the **DM CAM WF** tab at the top and from the menu on the right side of the screen. Here, you will be guided through all the relevant steps of the software.

DentaMile CAM MC workflow area with the most important software features

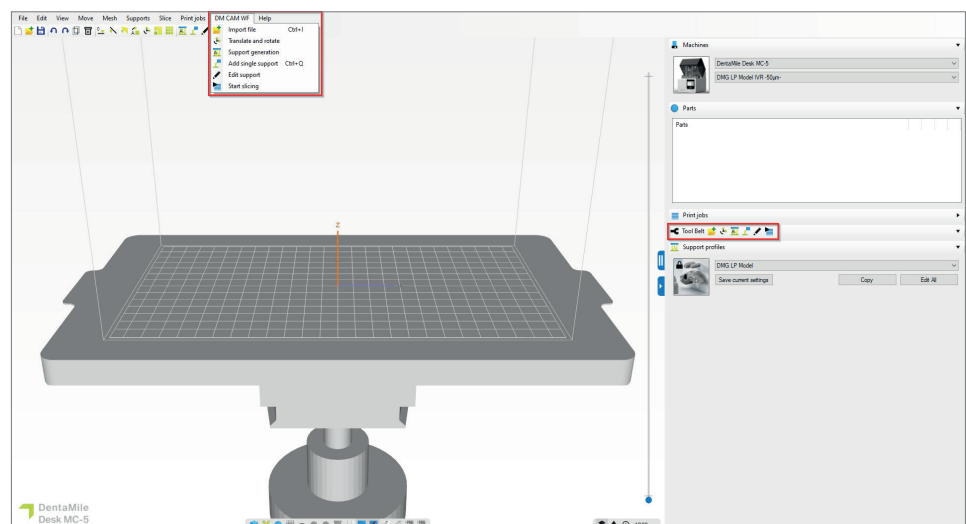

3.2.2. Importing the models and dies

Simply import the ready-prepared digital objects with drag-and-drop from the corresponding folder or click on **Import** and select the model files. Both of these options allow you to select several files at the same time, which means that you can transfer the model and stump data to the software all in one go.

Importing the model data into
DentaMile CAM MC

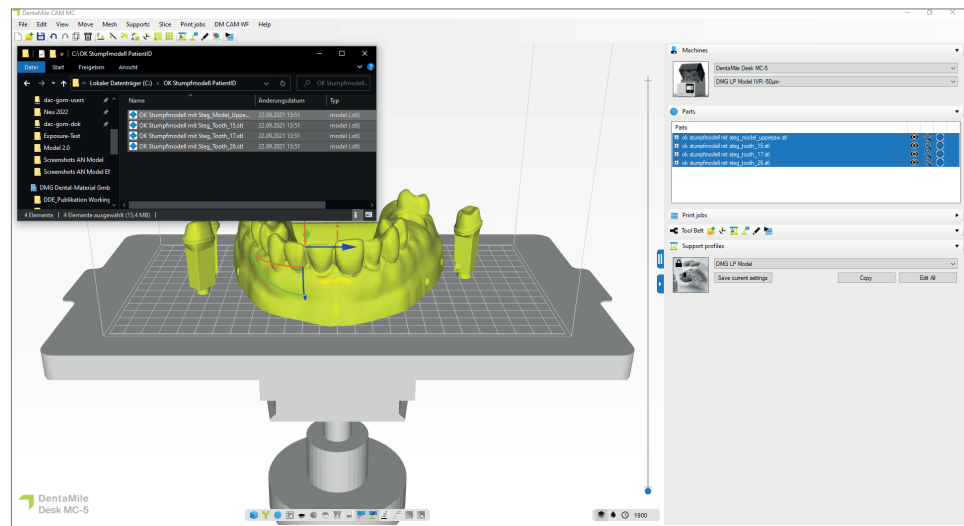

3.2.3. Aligning the models

In most cases, the model and dies will already have been correctly aligned inside the CAD software, so that no further action will be required. The model should rest flat on the build platform surface and the dies (if using the settings listed under 2.1) should also rest flat on the base.

If the objects are not correctly aligned, you can use the option **Select the area that is to be in contact with the build platform** in the top menu bar. Next, simply click on the area that is to be in contact with the build platform, e.g. the bottom edge of the base or the connecting bar, after which the software will move the component into the corresponding position. Next, proceed with the dies in the same way as with the model.

Aligning the models to ensure full contact with build platform

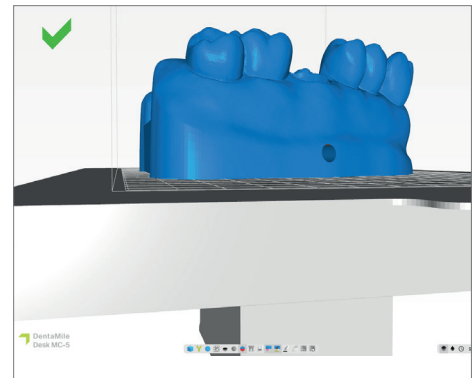
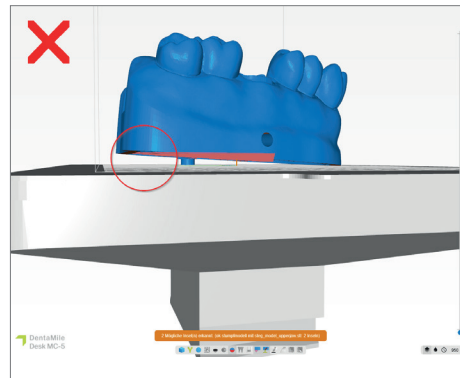

As soon as you are happy with the components' alignment and positions, please check whether all of them are properly resting on the build platform by looking at them from below.

Ready aligned models and dies in DentaMile CAM MC

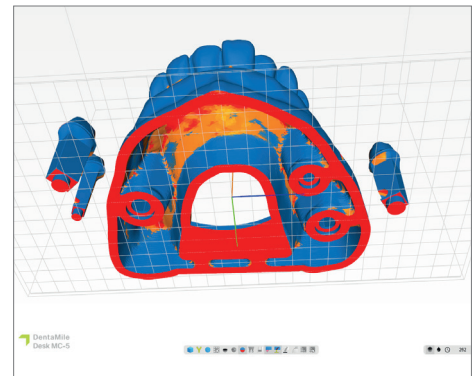
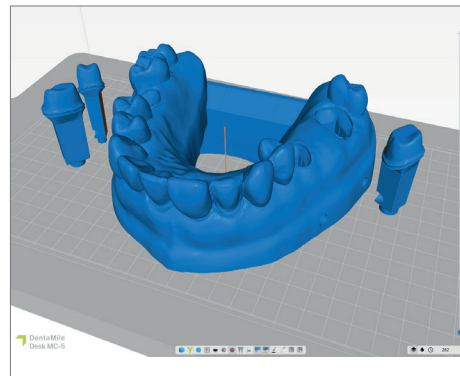

3.2.4. Add drain holes

If you haven't yet done so in the CAD software, it is easy to add drain holes to your model in DentaMile CAM MC.

Drain holes are crucial for allowing the liquid resin to flow out of hollow model. They also prevent the suction- cupeffect, which tends to occur when printing an object with an enclosed hollow space. The suction- cupeffect gives rise to higher pull-off forces during printing and hence to lower-precision print results, in particular in the area of the base.

Select **Add drain holes** under the **Grid** tab. Next, select the internal and external hole diameter in the dialogue window. The default setting of 3 mm is sufficient for ensuring good resin drainage and pressure equalisation.

Add drain holes and default settings

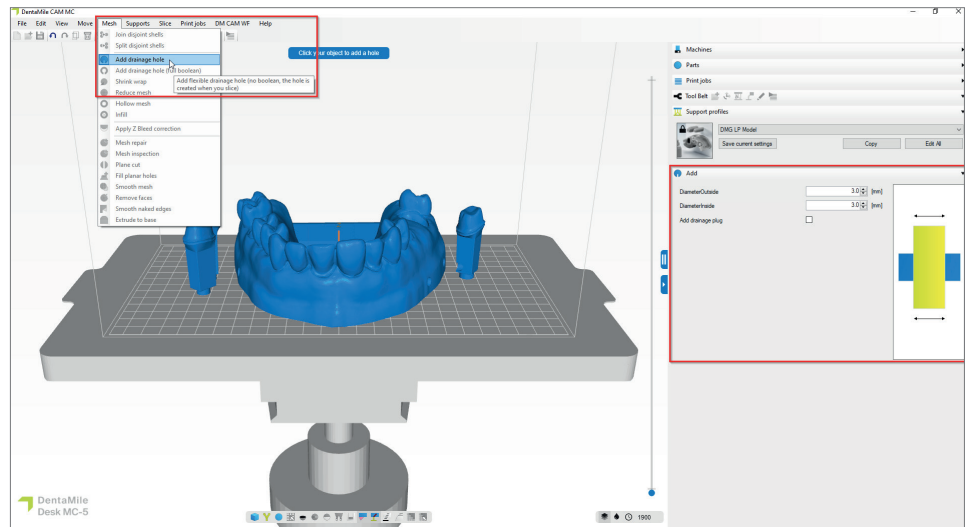

Now add drain holes to your model by clicking on the base area of your model. Three to five holes are ideal. The holes can be directly on the build platform as well as slightly higher in the model's base area.

Add drain holes.

Option 1) At the level of the build platform, Option 2) In the lower part of the model's base

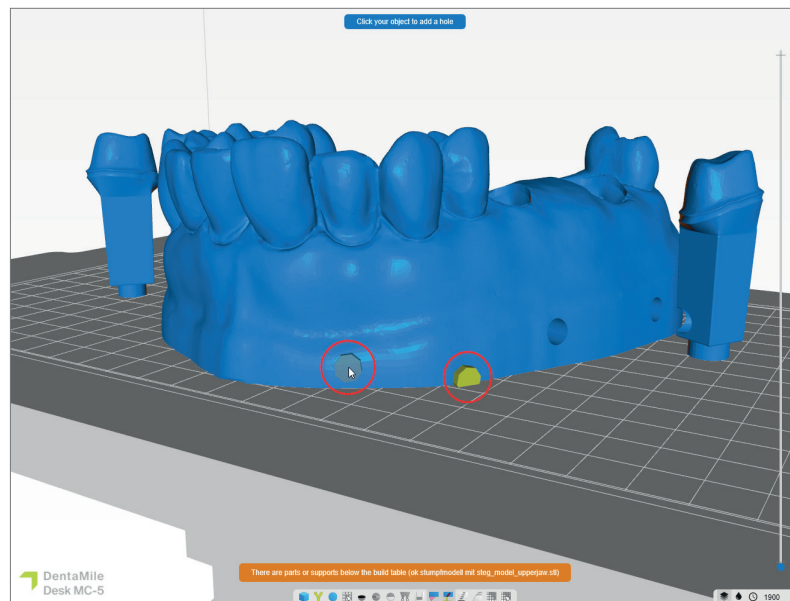

As soon as you have added the drain holes, you can close the dialogue box by clicking **Escape** and then continue creating the support structures.

3.2.5. Adding support structures

Due to the fact that the models are usually printed directly on the build platform, there is not necessarily any need for support structures. However, when printing hollow models, it is still advisable to use them to increase the objects' stability during printing and hence to prevent printing errors and achieve a higher level of accuracy.

Start by selecting your model (not the dies by left-clicking on them. The selected component will then turn yellow. Next, select **Create supports** and the relevant support profile **version** in the DentaMile CAM MC workflow area. Click on the Advanced tab and then on **Automatically create selected** to create the supports.

The tooth dies do not require any support structures if they have been created with the above parameters because they will be securely resting on a small base (or pin).

Cross section of the model and support structures

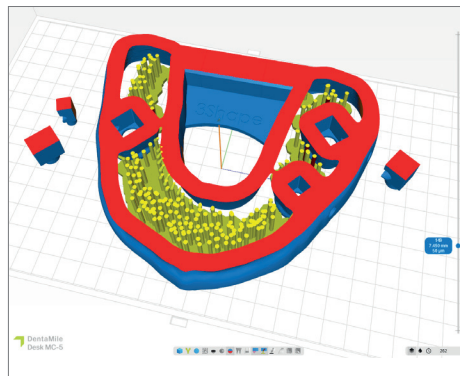

3.2.6. Creating a build job and transferring it to the printer (slicing)

Once you are happy with the way the models and dies are arranged on the build platform, you can start the slicing process by clicking on **Start slicing**.

In the next dialogue window, you can give your print job a new name or accept the suggested one. Next, select an outgoing directory, which has to be a folder on your computer's local hard drive. This is where the print job will be saved. You can now also check all of the system and material parameters again and change them. Click on **OK, start slicing** to generate the build job.

Slice overview in DentaMile CAM MC

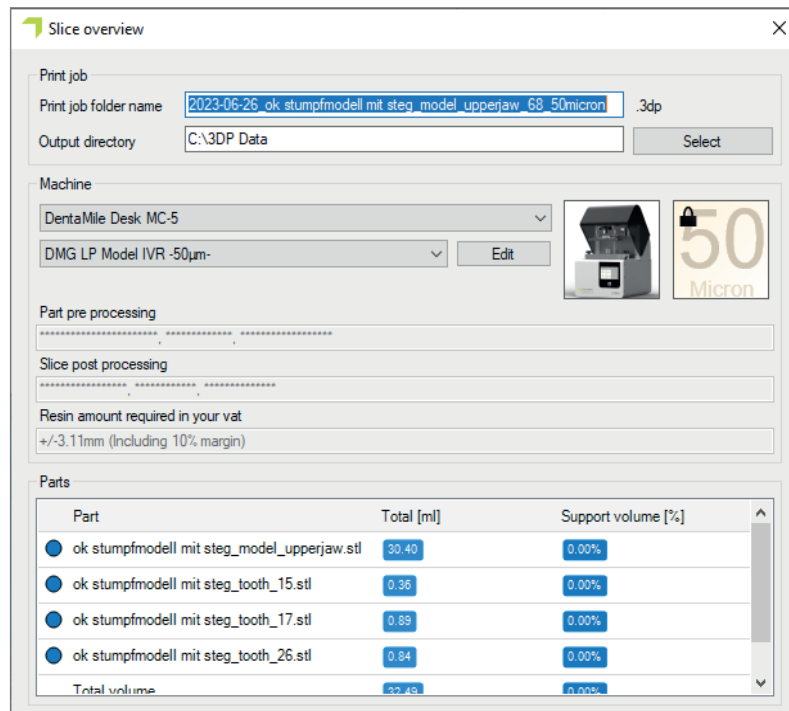

Now, transfer the finished print job to your 3D printer via the web interface or USB stick.

3.3. Asiga Composer for Asiga 3D printer (e.g. Asiga MAX UV)

3.3.1. Selecting the material and machine

Open Asiga Composer and select a new project or open a previously saved project. Select your printer and the material **LuxaPrint Model (DMG)** in the corresponding colour option as well as the required layer thickness (for stump models, we recommend 50 µm).

If you have not yet worked with the material, you can download the print parameters on the Asiga website in your account area in the material library (myaccount.asiga.com/accounts) and import them into the Composer software using the wheel next to the material selector.

Material and layer thickness selection in Asiga Composer

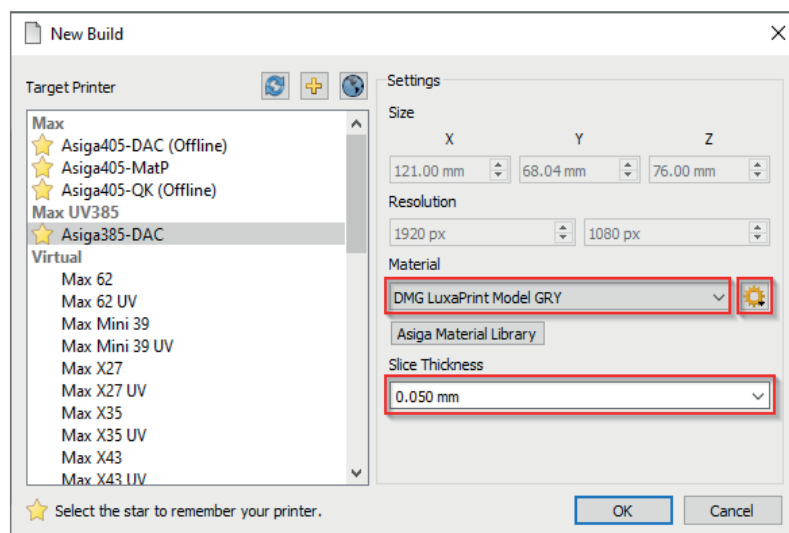

3.3.2. Import STL files

Import the previously-created model design into Asiga Composer. To do so, simply drag-and-drop the files into the software's 3D view area or select **Add objects ...** You can also import multiple files at once (e.g. models and stumps) by selecting all files and dragging them into the software.

3.3.3. Aligning the models and stumps in the build area

Start by arranging the objects on the build platform. When using the Composer, make sure to only do so looking down on them from above to make sure that the objects' bases are on the build platform.

Aligning the model in the Asiga Composer, viewed from above

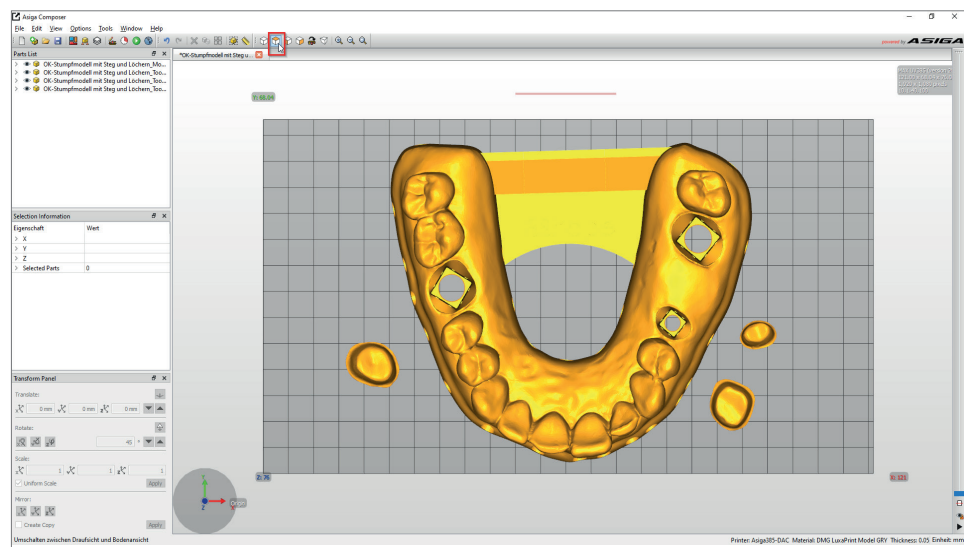

In most cases, the models and dies will already be aligned the right way when they are uploaded into the software, which means they generally do not need to be moved. However, please still check whether all of the objects are resting on the build platform by looking at them from the front and side.

The **Turn bevel down** function (in the transformation panel at the bottom left by the rotate function) can be useful when aligning upside-down objects. Once you have selected the relevant object, select the above option and click on the surface that you want to contact the build platform (which is generally the bottom of the model). The object will subsequently align itself automatically and should then be resting on the build platform with the selected surface.

Next, proceed with the stumps in the same way as with the model. In most cases, the dies will already be arranged vertically on the build platform after the import. If that isn't the case, please use the **Turn bevel down function**.

Finish by taking a look at the objects from below to make sure that they are all in adequate contact with the build platform.

The area where the objects are in contact with the build platform will be shown in a different colour.

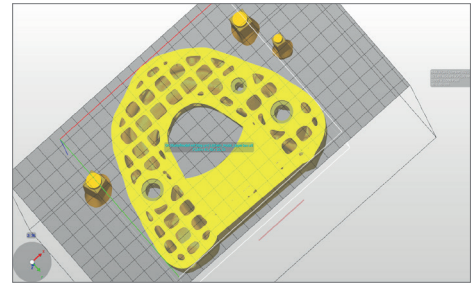
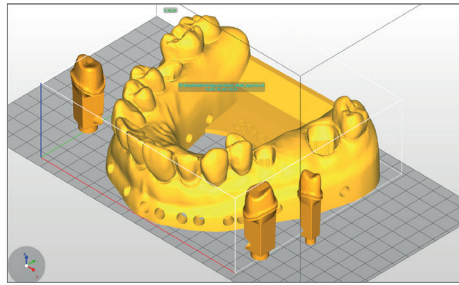

3.3.4. Adding support structures

Due to the fact that the models are usually printed directly on the build platform, there is not necessarily any need for support structures. However, when printing hollow models, it is still advisable to use them to increase the objects' stability during printing and hence to prevent printing errors and achieve a higher level of accuracy.

Start by selecting the model or models (not the dies and click on **Create support** in the menu bar. At the top of the support window, select the support objects: **Selected** and deactivate the height adjustment. All of the other options will already have been optimised for the material and do not need to be changed. Clicking on **Apply** will cause the software to compute the ideal position of the support structures and insert them between the model and build platform.

Composer support settings

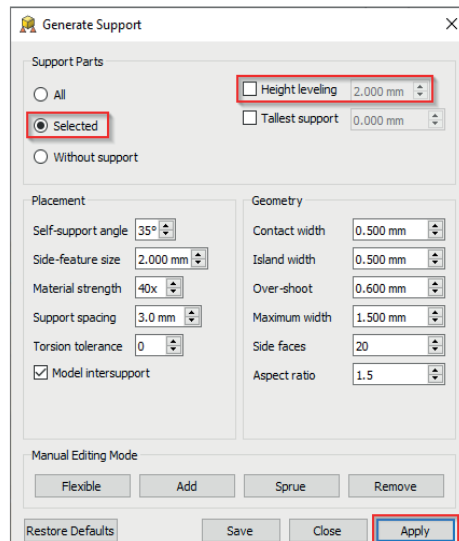

Please check the model to make sure all of the support structures are in the right place. To ensure that the dies will have a perfect fit, make sure that there are no support bars inside the stump sockets. If necessary, remove individual support bars and/or add additional ones.

Left image:
Removing individual support structures

Right image
Adding individual support structures

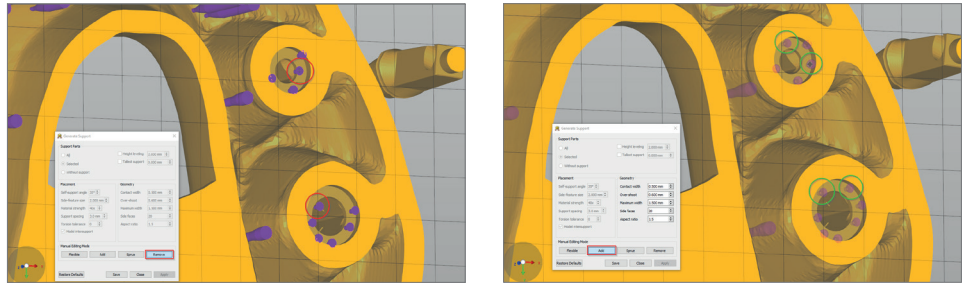

The tooth dies do not require any support structures if they have been created with the above parameters because they will be securely resting on a small base (or pin).

Once the object has been positioned and aligned and the supports have been created, your model with the dies should look as follows:

Checking the support structures and contact areas from below

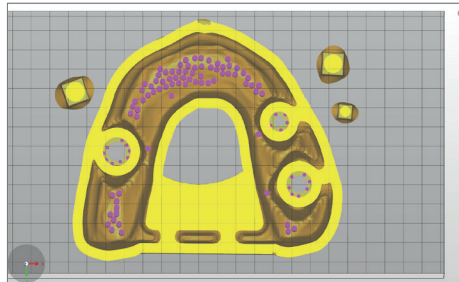

The yellow areas show where the objects are contacting the build platform. The model shown here is making adequate contact with the build platform and can therefore be printed without any problems.

3.3.5. Adding the baseplate and sending the print job to the printer

A baseplate makes the model rest more securely on the build platform and increases its stability around the base. You should always use a baseplate when printing with LuxaPrint Model.

In Asiga, the baseplate is created just before the slicing process. Click on **Build** (the green **Play** icon in the menu bar) to open the Build wizard. This is where you can first check all of your settings again. Clicking on **Continue** will then open the screen for creating a baseplate. Use the settings shown in the image to provide the model, but not the dies with a baseplate with holes.

Baseplate settings in Composer

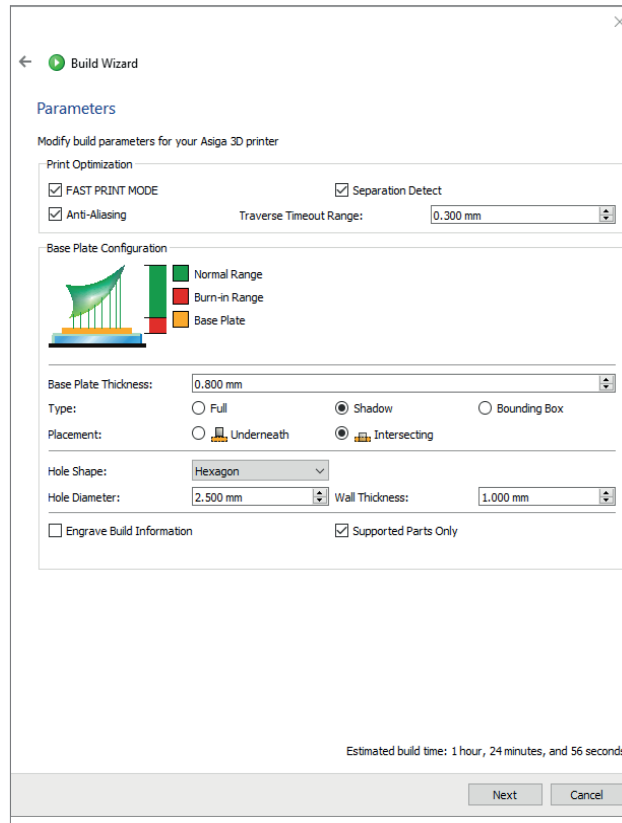

Clicking on **Continue** will allow you to check the Advanced parameters and then take you to the overview screen. Once here, you will need to give your print job a suitable name and then send it to the Asiga 3D printer. This is where you can also view the individual print views in black and white to give your print job a final check.

Print preview in Composer





4. Printing

≥1 min.



4.1. Shake the material

LuxaPrint Model (DMG) must be shaken for at least one minute before use. This ensures that you always achieve a homogeneous product and thus consistently high-quality results.

4.2. Scanning RFID tags

Scan the material's RFID code for greater process reliability. The device can detect incorrect material information in the software and will warn you if necessary (supported by DMG 3Demax/DMG 3Delite (DMG), D30/D20 + /D20 + cartridge/D10 + (RapidShape), P20 +/P10 + capsule (Straumann)).

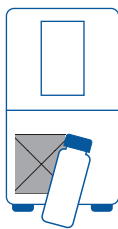

4.3. Adding printing material

Put LuxaPrint Model material in the resin reservoir of your 3D printer. Make sure that the reservoir is filled far enough, so that the resin can continue to flow even if the build platform is fully occupied. Please never fill the resin reservoir to the brim, as the resin may overflow and contaminate your printer.

4.4. Starting a 3D printing job

Start the print job on your 3D printer.

PRACTICAL TIP

If the relevant LuxaPrint Model material has been stored overnight or for a longer period in the printer's material tray, it will need to be stirred. When doing so, we recommend using a silicon scraper, spatula or similar to avoid damaging the material tray.

5. Post-processing

INTELLIGENT CONNECTIVITY

As a user of a DMG 3D printing system consisting of 3Demax, 3Dewash and 3Decure, you can benefit from the intelligent linking of the devices. As soon as the print job is finished on the printer, all relevant information is transferred to the post-processing devices, where you only have to select the appropriate print job to start the individual post-processing.



5.1. Draining

After completing the printing process, let your splints hang in the printer for about 10 minutes, so that any liquid resin can drip off. This saves material and cleaning.

PRACTICAL TIP

Use the drip aids (dripping rabbit) to enable the liquid resin to drip even faster and more effectively off your print objects. This saves print material and will reduce the number of times the isopropyl alcohol of your cleaning unit will need changing.



The print data for printing the drip aid can be downloaded directly from the DentalMile website at: [://www.dentalmile.com/de/news/detail/ostern-ist-vorbei-aber-der-abtropfhase-leistet-immer-gute-hilfe](http://www.dentalmile.com/de/news/detail/ostern-ist-vorbei-aber-der-abtropfhase-leistet-immer-gute-hilfe)



Removing the printed models from the 3Demax

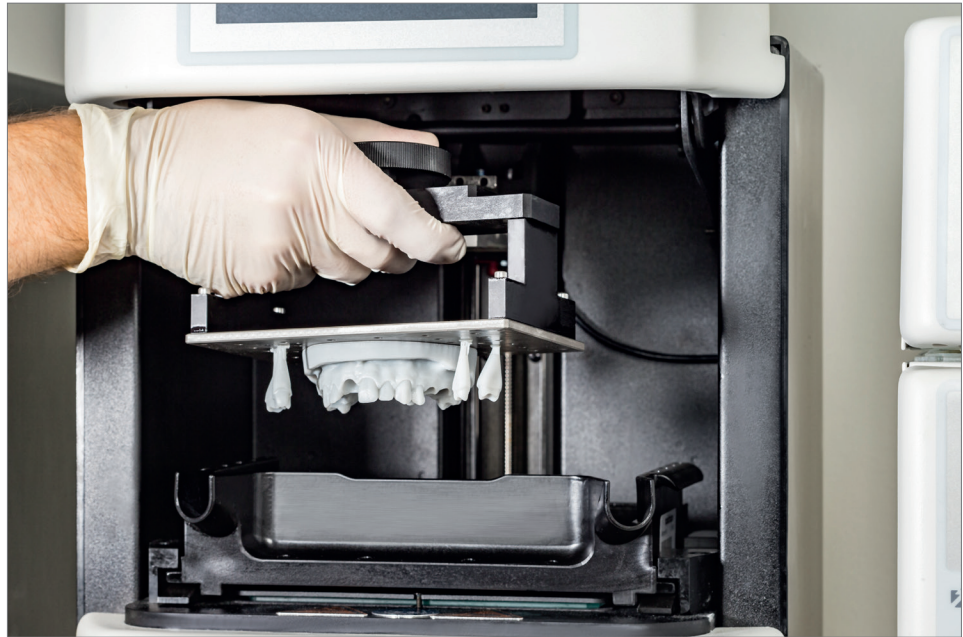

5.2. Detaching pieces from the build platform

Carefully detach printed objects from the build platform. To do so, use the scraper supplied with the printer, a cutter knife, a razor scraper or similar tool. Keep the blade as flat as possible and push it between the build platform and object. The object should then slowly but surely detach from the build platform.

CAUTION!

Please be careful when using razor blades, cutter knives or other sharp blades. Never cut material in the direction of your hand or body!

With DentaMile Desk MC-5, models can be quickly and easily removed from the build platform by removing the magnetic plate from the build platform and gently bending it.

Some models can be more difficult to remove from the build platform. In this case you can hold a scraper against the object and build platform and then gently tap the handle with a hammer. The model should then detach from the build platform without any problems.

Detaching the printed objects from the build platform

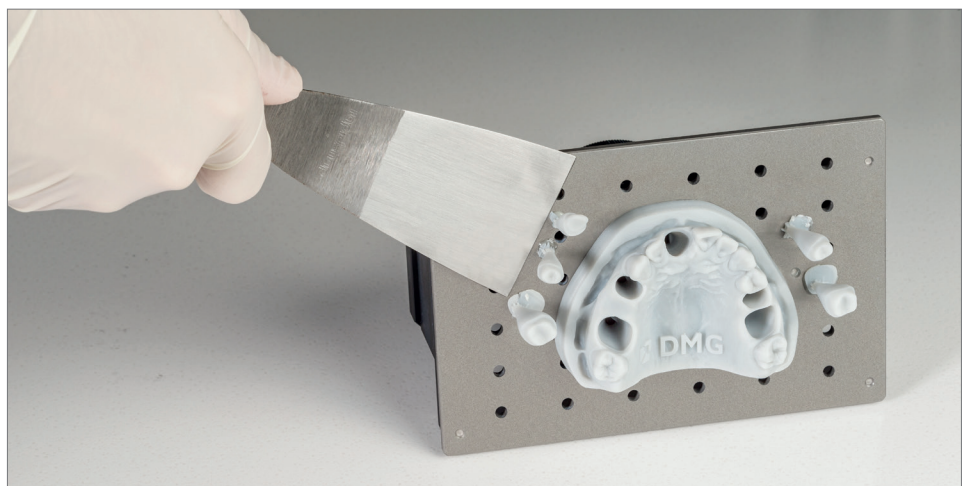

PRACTICAL TIP

Prolonged contact with the cleaning agents can affect the accuracy of the objects as well as their mechanical properties. Hence, please keep to the times stated here and remove the components from the units as promptly as possible after cleaning.

5.3. Cleaning

Once printed, the dental models have to be thoroughly cleaned to remove the liquid resin residues from the component surface. Please use the cleaning options (see Introduction) that have been designed and validated for your printing system.

5.3.1. DMG 3Dewash (or RS wash/P wash)

Simply place your printed parts in the cleaning chamber of the 3Dewash and select the program for LuxaPrint Model or the appropriate print job (requires Intelligent Connectivity). The dies should be cleaned using the supplied basket to prevent them from falling through the grating at the bottom of the unit and damaging the wash arms. The cleaning should be done with isopropyl alcohol (approx. 99%).

Detaching the printed objects from the build platform

**5.3.2. DMG DentaMile Wash MC**

Put the printed models and dies into the cleaning tray of the DentaMile Wash MC. Small dies should be cleaned inside a strainer to prevent them from falling into the gaps in the cleaning unit.

Select the cleaning program **Low** and set the timer to 5 minutes for thoroughly cleaning the printed objects.

PRACTICAL TIP

The cleaning solution in the container is going to start getting dirty once it has been used a number of times. Once that happens, you can use it to replace the container previously used for the prewash, which will be more heavily contaminated by now, and will need to be properly disposed of. You can then use a new isopropyl alcohol container as the main cleaning container.

5.3.3. Ultrasonic bath

If you do not have any of the above cleaning devices, you can also clean your model in an ultrasonic bath with isopropyl alcohol (99%). To do so, we recommend using two separate cleaning containers. The first for a prewash (max. 3 minutes) for removing most of the resin from the parts. This container will quickly become contaminated with resin, but can be continued to be used for prewashing other parts. The second container should contain fresh isopropyl alcohol and be used for fully removing all of the remaining resin residues (max. 2 minutes).

Step 1 (Prewash)	Ultrasound	Isopropyl alcohol	3 min
Step 2 (Main wash)	Ultrasound	Isopropyl alcohol (fresh)	2 min
Drying	Compressed air/air		10-60 s / 10 min

5.3.4. Final inspection

Ensure the models have completely dried before you proceed with post-curing. Use compressed air for this, or let the pieces air dry for about 30 minutes.

Drying a model with oil-free air



Inspect the parts thoroughly after drying and ensure that:

- the models are clean and completely dry,
- no cleaning fluid or resin residues remain on the surface (indicated by a shiny object surface),
- no imperfections or solid resin particles can be found on the surface.

If there are still liquid resin residues on the objects, they can be removed e.g. with a spray bottle containing isopropyl alcohol or a cloth soaked in isopropyl alcohol. Then dry your splints completely as described above.

PRACTICAL TIP

Post-curing that is too short, too long, or too intensive can lead to a loss of accuracy due to distortions in the part and discolouration of the pieces.

5.4. Post-curing

Correct post-curing of the printed pieces is important to obtain models with optimal mechanical properties, perfectly fitting dies and the correct dimensions. Hence, make sure to select the correct post-curing settings and adhere exactly to the given specifications. Please use the post-curing systems that have been specified and validated for your printing system as listed in the introduction.

Never stack your printed and cleaned objects on top of each other inside the post-curing devices, leave plenty of space and make sure that they will be exposed to light on every side.

Leave the objects to cool for 5-10 minutes after the post-curing process. Thanks to the way the models and dies are designed, there is no need for any further post-processing and they can be used immediately.

Post-curing in the 3Decure



5.4.1. DMG 3Decure (or RS cure/P cure)

Place your printed objects inside the exposure device chamber and select the program for your LuxaPrint Model (DMG) colour variant or the relevant print job (requires Intelligent Connectivity).

5.4.2. DMG DentaMile Cure MC

Place your printed objects inside the exposure device chamber of the DentaMile Cure MC and select the program for your LuxaPrint Model (DMG) colour variant.

5.4.3. Otoflash / Heraflash / HiLite Power3D

Place your printed objects in the chamber of the exposure device and cure using the settings given below.

Light-curing unit	Light-curing time	Tips
Otoflash G171 (N360 bath)	2 x 2,000 flashes	After the first 2000 flashes, let the printed object cool down and turn it over
Heraeus Heraflash/ Kulzer HiLite power 3D	2 x 180 seconds	After the first 180 seconds, let the printed object cool down and turn it over

5.5. Die fitting for models with removable dies

Following the completion of the entire digital and validated DMG workflow process, you should now be in possession of perfectly fitting dies

Due to the uniqueness of each model, individual model design modifications, minor variations in the workflow or the use of different printing, cleaning or post-curing devices, there is always a possibility that, even with our recommended settings, there is too much space around the dies in the sockets or that they do not fit into their intended ones. This section contains a number of tips for working with dies that do not fit.

5.5.1. The socket is slightly too small, the die doesn't fit or requires significant force to fit

Use a conventional release agent or lubricant to push the die into the socket and push it in and take it out a few times in a row. This should make it fit properly after a while.

Check both the die and socket for potential faults that may have been caused during the printing process or for resin residues that were not fully removed during the cleaning process.

5.5.3. You have single die that is too loose or tight while all of the others fit really well

exocad:

The Model Creator's expert mode contains a function for adjusting the **Dynamic gap width**. This is where you can specify that dies that are larger than a given size are provided with a different gap width than the other stumps. This function generally makes it possible to define settings that will produce a perfect fit. The settings defined here should also apply to all of the models produced using the same workflow.

Other model creators (e.g. 3Shape):

Check whether changing the gap width will make it possible to ensure that all dies will have a good fit. If, for example, a small die is fitting too tightly while the larger ones are fitting well, then using a marginally larger gap width that will not impact on the fit of the larger dies would ensure that the small die has a better fit.

If the dies are still not fitting properly, check whether a model with a mixture of fixed and removable dies might be an option for the restorative work (see the practical tip under 2.1.1). This would eliminate the issue and would produce a perfect model with perfectly fitting dies with every print.

6. Validated fitting accuracy

In our digital application centre, the fitting accuracy of all of our materials and workflows are set, checked and evaluated according to a defined validation process. Each workflow must meet strict criteria that have been developed for each application individually and according to clinical relevance and applicability.

The clinical acceptance limits for the accuracy of dental models are based on the restorative or orthodontic work that they are used for.

For restoration work, it is generally accepted that the size of the marginal gap is decisive to the clinical success of the work. A number of laboratory studies have presented various examination methods that, amongst others, examine silicone mouldings of the marginal gap using optical and scanning electron microscopy [1, 2] or by slicing whole restorations [3]. Clinical methods are generally limited to tests based on haptics e.g. using a dental probe [4] or radiographic examinations [5]. In most cases, the clinical acceptance limits for the marginal gap of restorations are between 50 and 100 μm [6, 7, 8]. Hence, the target for the local accuracy of a 3D-printed tooth die is therefore a maximum deviation of 50 μm or a mean deviation of max. 20 μm .

The requirements for the global accuracy of printed models largely depends on the clinical acceptance of the orthodontic work performed with them, such as 3D printed bite splints or retainers. In a recent study, Spies [9] concluded that mean deviations of up to 174 μm with respect to the mating surface of bite splints is clinically acceptable. However, with mean deviations of 42 μm , conventionally manufactured splints actually exhibit significantly lower differences. The target for the global reproduction accuracy of 3D-printed models produced using DMG's validated workflow is therefore a mean deviation of 50 μm or maximum permissible deviation of 150 μm on a minimum of 80% of the area.

We analyse the accuracy of our workflow by scanning the printed model with a 3D scanner and comparing the scan with the digital source file. For restorative work, this involves evaluating a single tooth die and the preparation margin, and for the global accuracy, an evaluation of the entire relevant area of the model.

The model shown here has been produced using the DMG validated workflow and LuxaPrint Model material, the DMG 3Demax printer (50 μm layer thickness), DMG 3Dewash cleaning unit and DMG 3Decure post-curing unit.

6.1. Removable tooth die (local accuracy)

Die accuracy

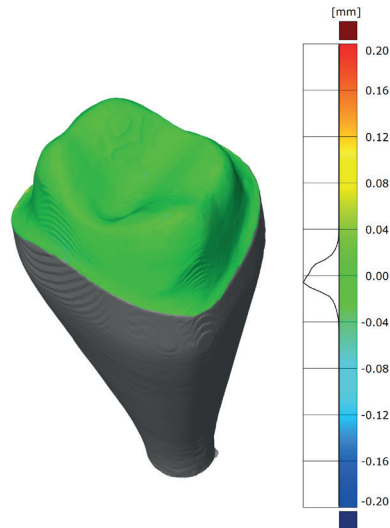

	Target	Result
Mean deviation	20 μm	9 μm
Max. deviation (80%-quantile)	50 μm	14 μm

6.2. Whole model (global accuracy)

Model accuracy

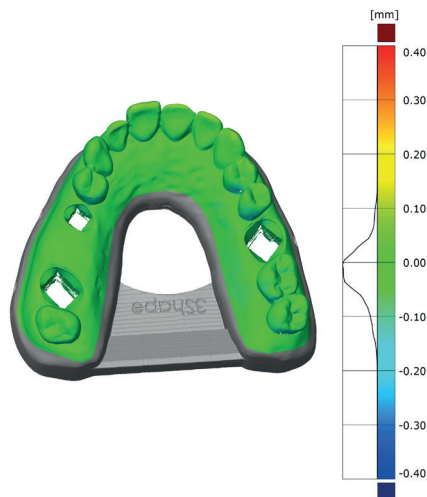

	Target	Result
Mean deviation	50 μm	41 μm
Max. deviation (80%-quantile)	150 μm	65 μm

The results of the accuracy analysis show that the printed objects produced with the above are within the clinical acceptance range and clearly meet or exceed the set targets. The printed models are therefore suitable for a wide range of restorative or orthodontic applications and for replacing classic plaster models.

6.3. References

- [1] Diedrich P, Erpenstein H: Rasterelektronenmikroskopische Randspaltanalyse von in vivo eingegliederten Stufenkronen und Inlays. Schweiz Monatsschr Zahnmed 1985, 95: 575-586
- [2] Groten M, Girthofer S, Pröbster L: Marginal fit consistency of copy-milled all-ceramic crowns during fabrication by light and scanning electron microscopic analysis in vitro. J Oral Rehabil 1997, 24: 871-81
- [3] Boening KW, Walter MH, Reppel P-D: Non-cast titanium restorations in fixed Prosthodontics. J Oral Rehabil 1992, 19: 281-287
- [4] Rappold AP, Ripps AH, Ireland EJ. Explorer sharpness as related to margin evaluations. Oper Dent. 1992 Jan-Feb; 17(1): 2-6.
- [5] Sharkey S, Kelly A, Houston F, O'Sullivan M, Quinn F, O'Connell B. A radiographic analysis of implant component misfit. Int J Oral Maxillofac Implants. 2011 Jul-Aug; 26(4): 807-15.
- [6] Dreyer Jørgensen K: Prüfungsergebnisse zahnärztlicher Gussverfahren. Dt.Zahnärztl. Z. 1958, 7: 461-469
- [7] Spiekermann H: Marginale Passform. Dt.Zahnärztl. Z. 1986, 41: 1015-1019
- [8] Pameijer JH, Westermann W: Von der erreichbaren Genauigkeit festsitzender Restaurationen. ZWR 1982, 91 (10): 46-49
- [9] Wesemann C, Spies BC, Schaefer D: Accuracy and its impact on fit of injection molded, milled and additively manufactured occlusal splints. J. Mech. Behav. Biomed. Mater. 2021, 114